

The Scully Ground Bolt & Ground Ball For the Scully Groundhog™

Vehicle Mounted Static Grounding devices For Tank Truck Grounding

Self-Proving For Maximum Safety and Performance

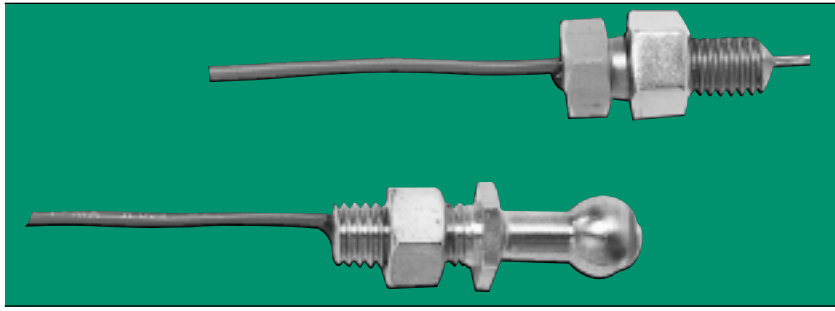

Scully Ground Bolt (top) and Scully Ground Ball (bottom)

The Scully Groundhog™ Vehicle Grounding System provides self-proving capabilities for maximum safety through electronic protection. Only the Scully Groundhog can offer you all these advantages for vehicle static grounding:

- Prevents Loading until a proper static ground has been established.
- Automatically shuts off the loading operation if the ground is broken at any time during loading.
- The Ground Ball and Bolt can be installed easily in a few minutes.
- Provides intelligent grounding verification with self-proving connections to the Ground Ball and Bolt.
- Self-proving feature provides visible proof that a proper vehicle static ground has been made and automatically permits loading.
- Suitable for tank cleaning and other applications where verifiable grounding is needed.
- Known for dependability, maximum safety and service common to all Scully Systems.

Description

The Scully Groundhog System insures your truck is at the same ground potential as the rack for safe loading conditions. Provisions are available where an earth tie-in is required.

If you load at terminals where the Scully Groundhog is incorporated with the existing Scully Overfill Prevention System, you need a Scully Ground Bolt on your vehicle. The Bolt is mounted directly to the vehicle frame and wired to the existing truck mounted Scully Socket(s). This allows you to perform only one connection for overfill and ground verification.

If you load at terminals which have a Scully Groundhog mounted independently at the rack, you need a Scully Ground Ball on your vehicle. The Ball mounts directly to the vehicle frame. The grounding connection is completed with a special quick release plug and cable assembly that plugs onto the ball.

The Scully Ground Bolt and Ball contain “smart” electronic circuitry which offers an intelligent return signal to the Groundhog Control Monitor. This “smart” circuitry must verify that a proper connection is made before loading can begin. If the ground connection is broken during loading operation, the operation ceases.

The Groundhog cannot be cheated like other grounding systems by attaching the clamp to the rack, putting a metal shim between jaws or jumping plug contacts.

Only the Scully Groundhog gives you a self-proving vehicle static grounding system this safe, this smart and this simple! With the Scully Groundhog, there's never a shadow of a doubt!

Setting New Standards In Safety

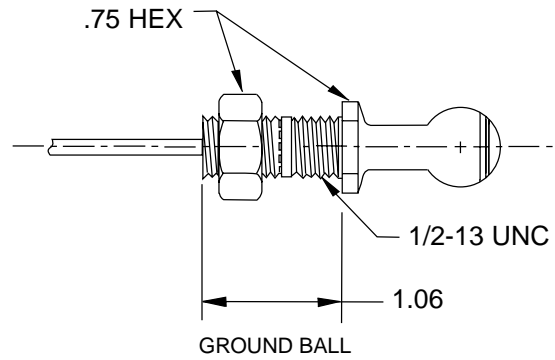
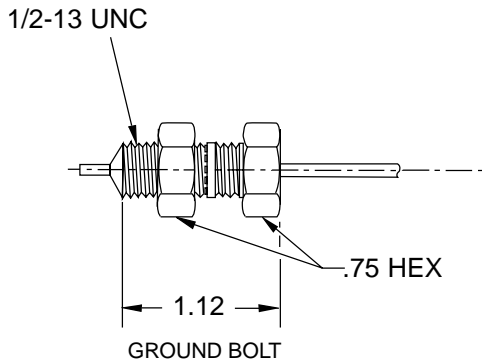

Technical Specifications

Ground Bolt
 Material : Stainless Steel, Stainless steel nut and lockwasher.
 Thread Size: 1/2-13 UNC
 Pigtail Length: 72" long
 Installation Torque: 125 inch pounds maximum

Ground Ball
 Material : Stainless Steel, Stainless steel nut and lockwasher.
 Thread Size: 1/2-13 UNC
 Ring Lug: 1/4" through hole
 Pigtail Length: 12" long

Factory Mutual Research has approved both system options. The Canadian Standards Association has approved the independent system option. Consult the factory for specific details. The Groundhog™ System is patent protected in the United States and other countries by the Scully Signal Company.

Two Simple Options for Maximum Grounding Safety



With The Overfill Prevention Plug



With The Independent Groundhog™ Plug

Ordering Information

If you load where the Scully Groundhog is connected to the Scully Overfill Prevention Monitor, order the Scully Ground Bolt. If you load or Unload where the Scully Groundhog is an independent system using a separate Ground Ball plug and cable, order the Scully Ground Ball

Model	Description	Part#
Ground Bolt	Truck mounted electronic ground proving bolt for direct wiring to the Scully Overfill Prevention Socket (integrally wired system)	08560
Ground Ball	Truck mounted electronic ground proving ball for direct wiring to SC-47 ground plug (independent system)	08274

*Biclops, Dynacheck, Dynamic Self-Checking, Dynamic Self-Test, Faylsafe, Intellicheck, Intellitrol, Intelliview, load Anywhere, Maxxsafety, MulteCept, Scully, Scultrrol, Scul-Lock, Scul-Tel, Scul-Tite, TABS and V.I.P. are registered trademarks of the Scully Signal Company
 Specifications are subject to change without notice*

Worldwide Contact
 Scully Signal Company
 70 Industrial Way
 Wilmington, MA 01887 USA
 Tel: 1-800-272-8559 or (617) 692-8600
 Fax: (617) 692-8620
 email: sales@scully.com
 www.scully.com

