

LPM-200

2" LP-Gas Flowmeter

Product Bulletin

LISTED
91U3

Designed for bobtail tank trucks and bulk plants, the LPM-200 offers the widest flow range, (20-100 gpm) available in a meter of this type. The LPM-200 utilizes a durable, all-ductile-iron housing for reliability, durability and years of low-maintenance use. In addition, the flowmeter is self-contained with all required accessories including vapor eliminator, strainer and differential valve.

Available in a variety of configurations for every application, the LPM-200 can be ordered with registration calibrated in U.S. gallons or liters. Automatic temperature compensator is available. The Full-Circle *Quick-Vent* option allows safe and effective evacuation of the meter for maintenance and repairs.

The LPM-200 is completely compatible with the Neptune® 2" Type 4D flowmeter; both in external dimensions and its internal parts. The unit is UL Listed, and has received NTEP Certificate of Conformance #96-112A1.

Primary Features

At the heart of the model LPM-200 flowmeter is the superior Liqua-Tech measuring chamber. It features a hard-coated piston with special dense metal oxide finish and hardened steel bearing shaft, field proven in thousands of installations. The meter is also available with Liqua-Tech's patented *Trac-Bearing*® measuring chamber option, for improved accuracy, reliability and lower maintenance. The *Trac-Bearing*® design controls and stabilizes piston rotation more efficiently than standard control rollers, resulting in greater sustained linear accuracy with less wear.

The LPM-200 is equipped with Veeder-Root printing or non-printing registers, for established reliability and lowest operating torque. The meter is also available configured with gear plate, star-driver, or spindle only for adaptation to electronic registration units. The exclusive Liqua-Tech register gear plate adapter offers Neptune style change gears for ease of calibration.

Neptune® is a registered trademark of Actaris Meter Systems. Liqua-Tech is an unaffiliated manufacturer of replacement parts for Neptune flowmeters.



Specifications

Rate of Flow: 20 to 100 gpm (80 to 380 lpm) maximum.

Working Pressure: 350 psi (24 bar) maximum (24.6 Kg/cm²).

Connections: 2" FPT on inlet check valve and differential pressure valve. Each is flanged to flowmeter for easy installation. Standard configuration has inlet at left-rear and outlet to right. Other combinations possible to suit the installation.

Register: Veeder-Root model 789002 (printing) or model 788700 (non-printing), with special Liqua-Tech VRA-Series gear plate adapter.

Units of Measure: Calibration is in U.S. gallons or liters.

Register Reset Capacity: 9,999.9 gallons, 9,999.9 liters.

Register Totalizer Capacity: 9,999,999.9 gallons 99,999,999 liters.

Temperature Compensator: Compensates to 60° F (15° C).

Operating Range: -10° F to 125° F (-23° C to 52° C).

Weight:

Without ATC, register or gear plate 152 lbs. (69 kg.)

With ATC and printing register 205 lbs. (93 kg.)

LPM-200

Standard Configurations

Non-Temperature Compensated

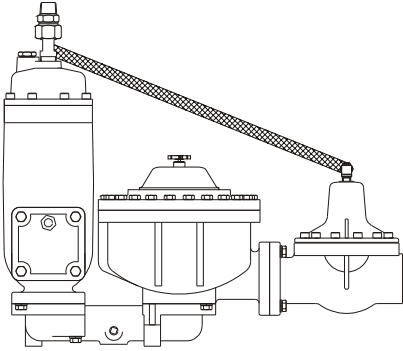

Without register or gear plate.

Part Number	Units of Measure
L090042-040	Gallons
L090042-050	Liters

Without register. Includes gear plate.

Part Number	Units of Measure
L090042-051	Gallons
L090042-053	Liters

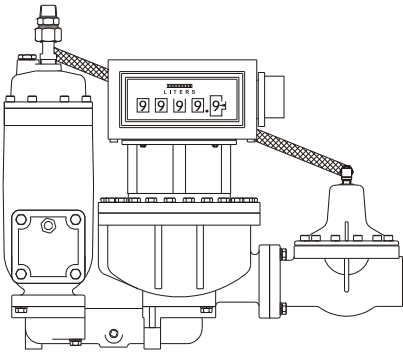
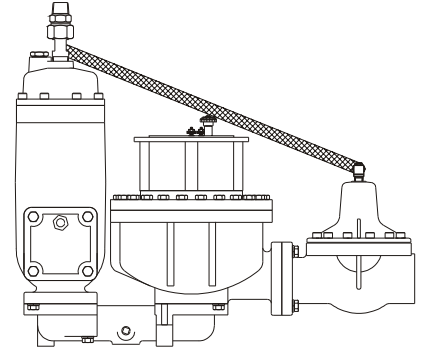

With Veeder-Root non-printing register.

Part Number	Units of Measure
L090042-101	Gallons
L090042-103	Liters

With Veeder-Root printing register.

Part Number	Units of Measure
L090042-102	Gallons
L090042-104	Liters

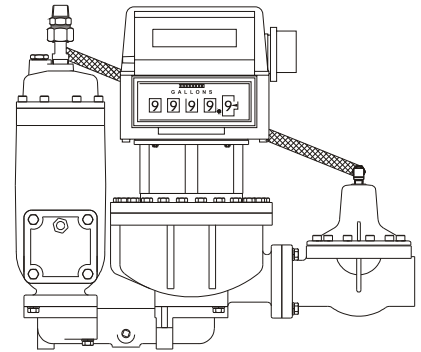

Automatic Temperature Compensation (ATC)

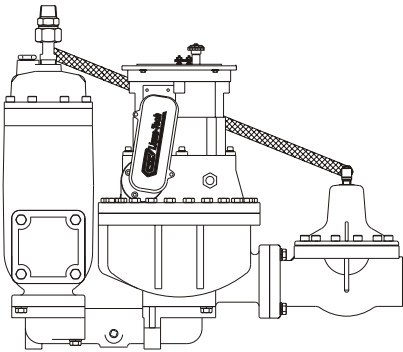

Without register. Includes gear plate and spacer.

Part Number	Units of Measure
L090042-109	Gallons
L090042-110	Liters

Without register. Includes Neptune-style upper drive bracket.

Part Number	Units of Measure
L090042-111	Gallons
L090042-112	Liters

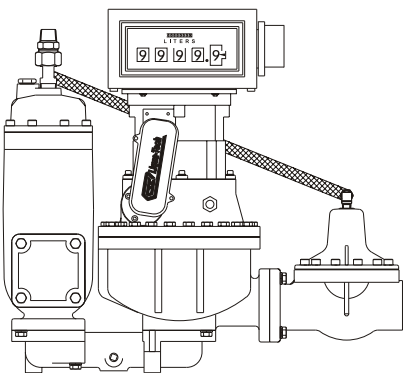
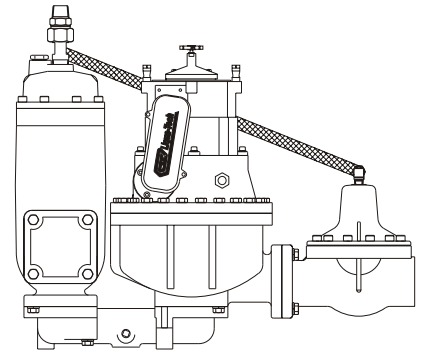

With Veeder-Root non-printing register.

Part Number	Units of Measure
L090042-105	Gallons
L090042-107	Liters

With Veeder-Root printing register.

Part Number	Units of Measure
L090042-106	Gallons
L090042-108	Liters

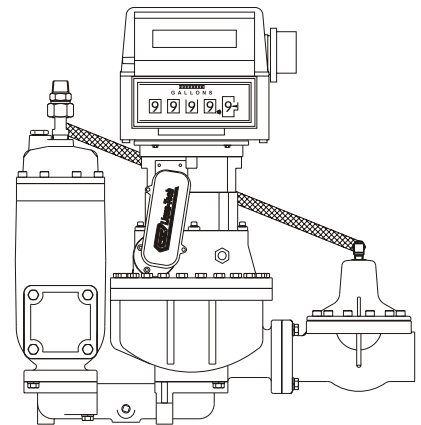

LPM-200

Replacement Parts

Meter Without Automatic Temperature Compensation (ATC)

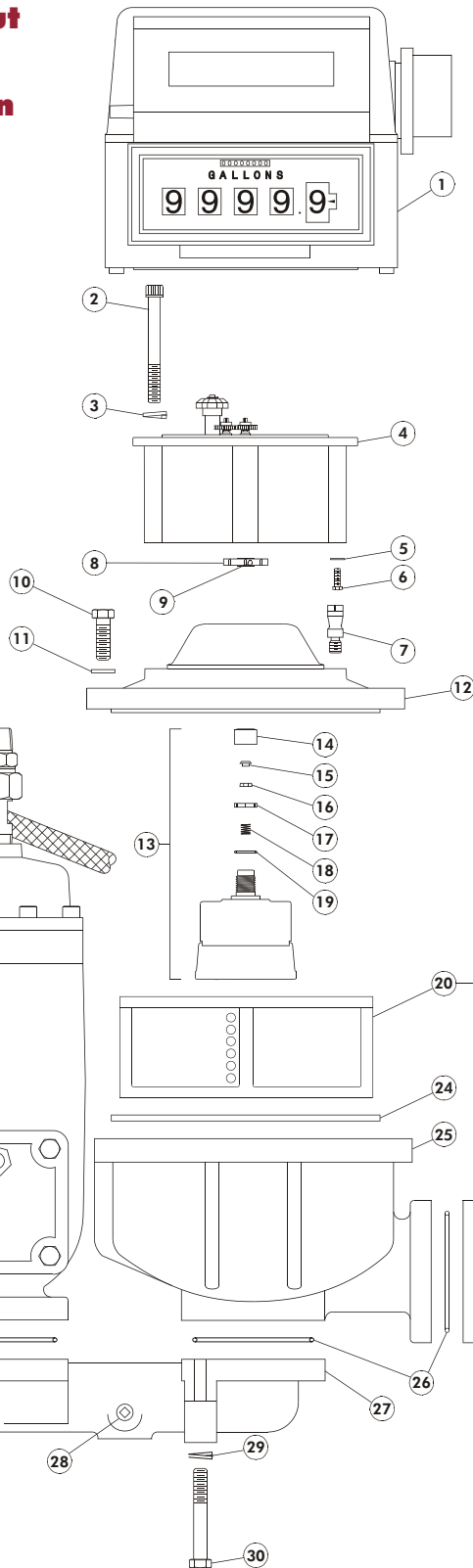

Ref.	Description	Part Number
1	Veeder-Root register, non-printing, US gallons	L788700-036
	Veeder-Root register, non-printing, liters	L788700-703
	Veeder-Root register, printing, US gallons	L789002-705
	Veeder-Root register, printing, liters	L789002-010
2	Screw, 3/8-16 x 3 1/2", socket head	L100072-001
3	Lockwasher, 3/8", high collar, steel	L100440-002
4	Adapter plate, for Veeder-Root register, non-ATC	L886201-001
5	Lockwasher, 1/4", star	L100123-100
6	Screw, 1/4-28 x 5/8", hex head	L100061-100
	Screw, 1/4-28 x 5/8", hex head, drilled	L100061-011
7	Stud, register mounting, stainless steel	L084435-000
8	Star driver, with setscrew	L082976-001
9	Set screw, 8-32 x 5/16"	L088796-000
10	Screw, cap, 7/16-14 x 1 3/8"	L000795-003
	Screw, cap, 7/16-14 x 1 3/8", drilled	L000795-011
11	Washer, 7/16", flat, steel	L000796-004
12	Main case cover, w/locking pin, no ATC	L084802-702
13	Gear train, 2", 3.75 ratio, LPG, 1 US gallon, clover driver	L083502-000
	Gear train, 2", 3.75 ratio, LPG, 1 US gallon, tear drop driver	L083502-005
	Gear train, 2", 9.93 ratio, LPG, 1 liter, tear drop driver	L080862-055
	Gear train, 2", 3.75 ratio, NH ₃ , 1 US gallon, tear drop driver	L087774-001
	Gear train, 2", 9.93 ratio, NH ₃ , 1 liter, tear drop driver	L087774-003
14	Nut, stuffing box, complete w/bushing	L083536-000
15	Clamp nut, gear train, LPG	L000034-000
	Clamp nut, gear train, NH ₃	L000034-004
16	U-cup seal, gear train, Buna-N	L100025-002
17	Expander, U-cup	L083539-000
18	Spring, stuffing box	L083540-000
19	O-ring, gear train, Buna-N	L100138-003
20	Measuring chamber, 2", LPG, standard	L045806-101
	Measuring chamber, 2", LPG, Trac-Bearing	L045806-501
	Measuring chamber, 2", food service	L045806-102
	Measuring chamber, 2", NH ₃	L045806-103
21	Seal pin, 2" measuring chamber (Liqua-Tech), LPG	L042546-010
	Seal pin, 2" measuring chamber (Liqua-Tech), NH ₃	L042546-012
	Seal pin, 2" measuring chamber (Neptune), LPG	L042546-000
	Seal pin, 2" measuring chamber (Neptune), NH ₃	L042546-002

Ref.	Description	Part Number
22	Control roller, 2" measuring chamber (Liqua-Tech), LPG	L042316-010
	Control roller, 2" measuring chamber (Liqua-Tech), NH ₃	L042316-014
	Control roller, 2" measuring chamber (Neptune), LPG	L042316-001
	Control roller, 2" measuring chamber (Neptune), NH ₃	L042316-004
23	Diaphragm, 2" measuring chamber (Liqua-Tech), LPG	L042312-010
	Diaphragm, 2" measuring chamber (Liqua-Tech), NH ₃	L042312-015
	Diaphragm, 2" measuring chamber (Neptune), LPG	L042312-001

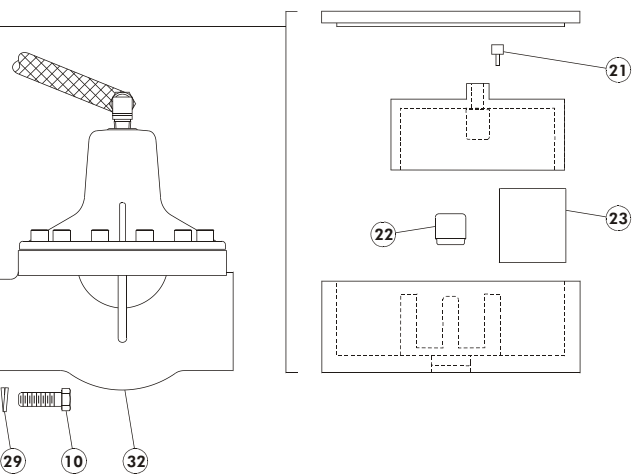

Ref.	Description	Part Number
23	Diaphragm, 2" measuring chamber (Neptune), NH ₃	L042312-005
NS	Repair Kit, 2" measuring chamber (Liqua-Tech)	L045806-702
	Repair Kit, 2" measuring chamber (Neptune)	L045806-701
24	Gasket, main case	L084806-000
25	Main case housing with locating pin	L084804-702
26	O-ring gasket	L100139-018
	O-ring gasket (square-cut)	L084818-000
27	Connector, meter to vapor eliminator	L086698-702
28	Plug, drain	L100075-003
29	Lockwasher, 7/16", steel	L041012-002
30	Screw, 7/16-14 x 3", hex head, steel	L100071-068
31	Vapor release and strainer assembly, complete	L084807-701
32	Differential valve, complete	L083925-701

LPM-200

Replacement Parts

Meter With Automatic Temperature Compensation (ATC)

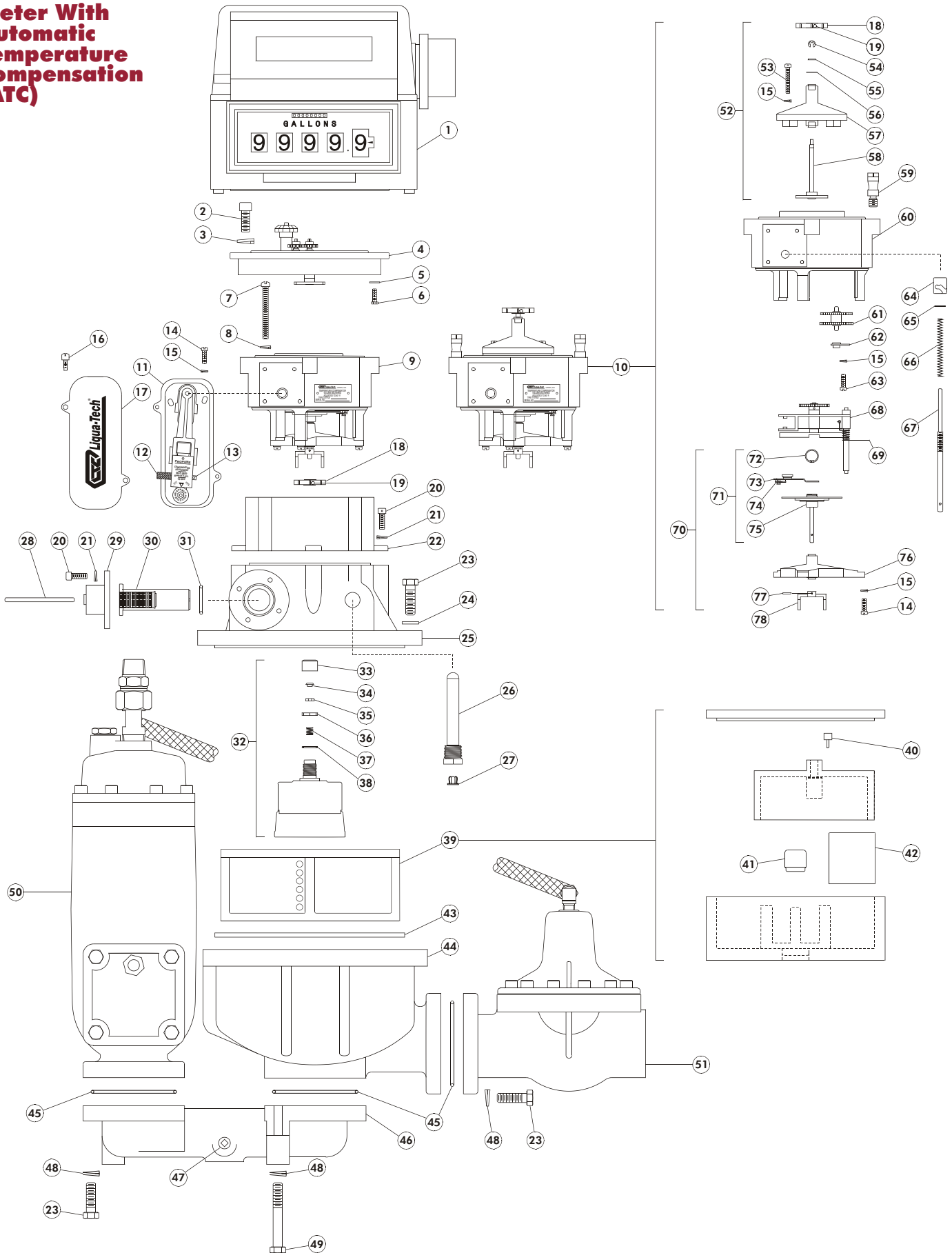

LPM-200

Replacement Parts

Ref.	Description	Part Number
1	Veeder-Root register, non-printing, US gallons	L788700-036
	Veeder-Root register, non-printing, liters	L788700-703
	Veeder-Root register, printing, US gallons	L789002-705
	Veeder-Root register, printing, liters	L789002-010
2	Screw, 3/8-16 x 1", socket head	L008325-014
	Screw, 3/8-16 x 1", socket head, drilled	L008325-015
3	Lockwasher, 3/8", high collar, steel	L100440-002
4	Adapter plate, for Veeder-Root register, ATC	L886205-001
5	Lockwasher, 1/4", star	L100123-100
6	Screw, 1/4-28 x 5/8", hex head	L100061-100
	Screw, 1/4-28 x 5/8", hex head, drilled	L100061-011
7	Screw, 1/4-20 x 2 1/2", filister head	L008302-107
8	Lockwasher, 1/4", high collar, steel	L088721-000
9	Temperature compensator adapter	L086602-101
10	Temperature compensator adapter, with upper drive bracket	L086602-005
11	Mounting plate and lever arm assembly	L086649-003
12	Pin, lever arm lock	L086661-001
13	Cotter pin, 1/16" dia. x 3/8", steel	L041401-000
14	Screw, 10-32 x 5/8" filister head, steel	L041221-002
15	Lockwasher, #10, steel	L041211-000
16	Screw, cover, 10-32 special	L009287-003
17	Cover, lever arm mounting plate	L086665-000
18	Star driver, with setscrew	L082976-001
19	Set screw, 8-32 x 5/16"	L088796-000
20	Screw, 1/4-20 x 3/4", socket head	L100060-010
	Screw, 1/4-20 x 3/4", socket head, drilled	L100060-011
21	Lockwasher, 1/4", steel	L041117-000
22	Spacer, aluminum	L086711-000
23	Screw, cap, 7/16-14 x 1 3/8"	L000795-003
	Screw, cap, 7/16-14 x 1 3/8", drilled	L000795-011
24	Washer, 7/16", flat, steel	L000796-004
25	Main case cover w/locking pin	L086704-701
26	Thermowell	L086666-702
27	Cover, thermowell	L083732-000
28	Pin, thermostat	L086648-000
29	Cover, thermostat	L086647-001
30	Thermostat bellows assembly	L086646-000
31	O-ring, thermostat bellows	L100139-005
32	Gear train, 2", 3.75 ratio, LPG, 1 US gallon, clover driver	L083502-000
	Gear train, 2", 3.75 ratio, LPG, 1 US gallon, tear drop driver	L083502-005
	Gear train, 2", 9.93 ratio, LPG, 1 liter, tear drop driver	L080862-055
	Gear train, 2", 3.75 ratio, NH ₃ , 1 US gallon, tear drop driver	L087774-001
	Gear train, 2", 9.93 ratio, NH ₃ , 1 liter, tear drop driver	L087774-003
33	Nut, stuffing box, complete w/bushing	L083536-000
34	Clamp nut, gear train, LPG	L000034-000
	Clamp nut, gear train, NH ₃	L000034-004
35	U-cup seal, gear train, Buna-N	L100025-002
36	Expander, U-cup	L083539-000
37	Spring, stuffing box	L083540-000
38	O-ring, gear train, Buna-N	L100138-003
39	Measuring chamber, 2", LPG, standard	L045806-101
	Measuring chamber, 2", LPG, Trac-Bearing	L045806-501
	Measuring chamber, 2", food service	L045806-102
	Measuring chamber, 2", NH ₃	L045806-103

Ref.	Description	Part Number
40	Seal pin, 2" measuring chamber (Liqua-Tech), LPG	L042546-010
	Seal pin, 2" measuring chamber (Liqua-Tech), NH ₃	L042546-012
	Seal pin, 2" measuring chamber (Neptune), LPG	L042546-000
41	Seal pin, 2" measuring chamber (Neptune), NH ₃	L042546-002
	Control roller, 2" measuring chamber (Liqua-Tech), LPG	L042316-010
	Control roller, 2" measuring chamber (Liqua-Tech), NH ₃	L042316-014
	Control roller, 2" measuring chamber (Neptune), LPG	L042316-001
42	Control roller, 2" measuring chamber (Neptune), NH ₃	L042316-004
	Diaphragm, 2" measuring chamber (Liqua-Tech), LPG	L042312-010
	Diaphragm, 2" measuring chamber (Liqua-Tech), NH ₃	L042312-015
	Diaphragm, 2" measuring chamber (Neptune), LPG	L042312-001
NS	Diaphragm, 2" measuring chamber (Neptune), NH ₃	L042312-005
	Repair Kit, 2" measuring chamber (Liqua-Tech)	L045806-702
43	Repair Kit, 2" measuring chamber (Neptune)	L045806-701
	Gasket, main case	L084806-000
44	Main case housing with locating pin	L084804-702
45	O-ring gasket	L100139-018
	O-ring gasket (square-cut)	L084818-000
46	Connector, meter to vapor eliminator	L086698-702
47	Plug, drain	L100075-003
48	Lockwasher, 7/16", steel	L041012-002
49	Screw, 7/16-14 x 3", hex head, steel	L100071-068
50	Vapor release and strainer assembly, complete	L084807-701
51	Differential valve, complete	L083925-701
52	Register (upper) drive bracket, complete	L084890-004
53	Screw, filister head, steel plated, 10-32 x 1 1/4"	L089073-000
54	Retaining ring, 3/16"	L886131-000
55	Washer, drive shaft	L008571-014
56	Shim, drive shaft	L886121-000
57	Bracket assembly, (upper) w/bushings	L086808-000
58	Gear & drive shaft complete (41 tooth)	L086554-001
59	Stud, register mounting, stainless steel	L084435-000
60	Adapter housing	L084921-003
61	Gear & shaft assembly (41 & 35 teeth)	L084907-001
62	Plate, idler gear retainer	L086609-000
63	Screw, 10-32 x 3/8", filister head	L088524-000
64	Swivel block assembly	L086612-000
65	Washer, spring retaining	L088286-003
66	Spring, push rod	L084888-001
67	Push rod	L086611-001
68	Arm complete, offset spider (31T gear)	L084910-003
69	Spring, offset spider	L086645-000
70	Lower drive bracket, complete	L084913-002
71	Ratchet wheel assembly w/arms	L084916-001
72	Ring, retaining	L086071-000
73	Ratchet arm assembly #1	L086057-001
	Ratchet arm assembly #2	L086064-001
	Ratchet arm assembly #33	L086637-001
	Ratchet arm assembly #44	L086639-001
74	Spring, ratchet pawl	L086063-000
75	Ratchet wheel/shaft assembly	L084917-001
76	Drive bracket w/bushings	L084914-000
77	Roll pin, 1/16" x 3/8", steel	L100370-003
78	Driver fork	L084192-006

LPM-200

Replacement Parts

Vapor Eliminator

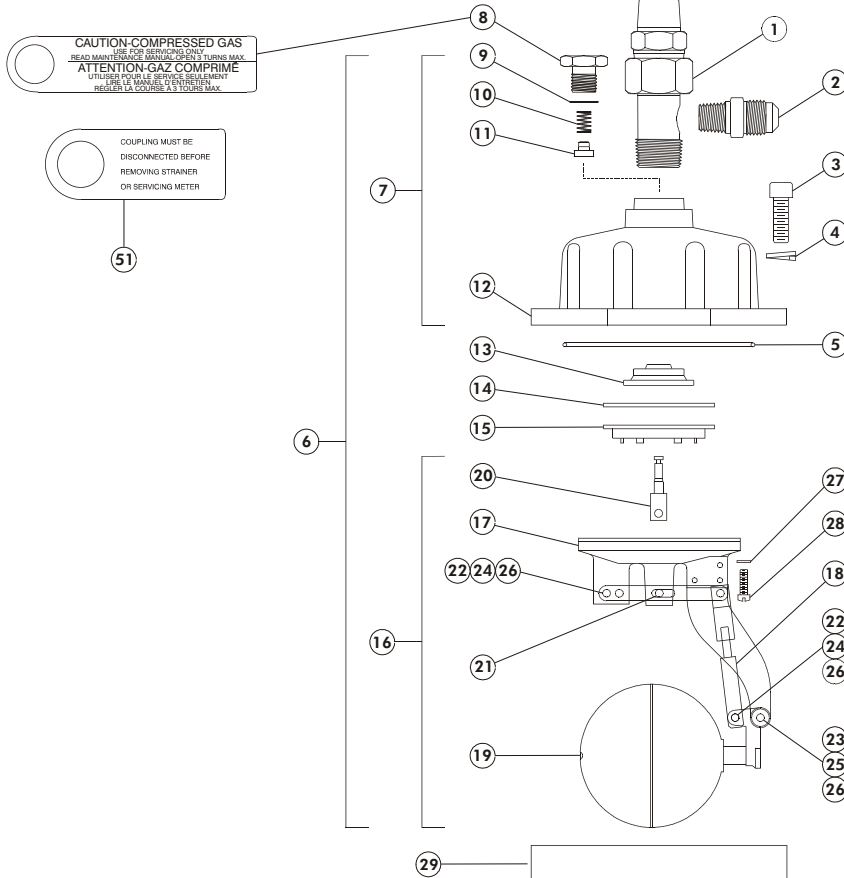

Ref.	Description	Part Number
1	Valve, vapor return check	L084828-000
2	Fitting, straight, 3/8" male flare	L084826-000
3	Screw, 3/8-16 x 1" socket head	L008325-014
4	Lock washer, 3/8" steel, high collar	L100440-002
5	O-ring, vapor release cover	L100139-022
6	Mounting cover w/float valve	L084808-701
7	Cover assembly, vapor release	L100148-001
8	Screw, pressure relief (includes caution tag)	L100333-001
9	O-ring, pressure relief screw	L100138-006
10	Spring, compression	L100024-003
11	Valve assembly, bypass	L100237-001
12	Cover, vapor release	L100147-901
13	Main valve, complete	L089274-006
14	Piston seal	L083179-000
15	Sleeve, valve	L082446-005
16	Lower valve housing, complete	L086798-001
17	Valve housing with extensions	L083457-000
18	Link assembly	L080002-000
19	Float complete	L082476-001
20	Valve stem	L083127-001
21	Pin, valve stem	L042941-000
22	Pin, short (.68")	L082633-000
23	Pin, float to lever, long (1.37")	L040820-003
24	Washer, pin (short)	L041989-000
25	Washer, float lever pin (long)	L040491-000
26	Cotter pin, 1/16" x 1/2", 304 SS	L041402-000
27	Screw, 10-32 x 5/8", filister	L041221-002
28	Lock washer, #10, steel	L041211-000
29	Body, vapor release & strainer	L084810-701
30	Strainer, 84 mesh (standard)	L101462-004
	Strainer, 60 mesh	L101462-003
	Strainer, 40 mesh	L101462-002
	Strainer, 16 mesh	L101462-001

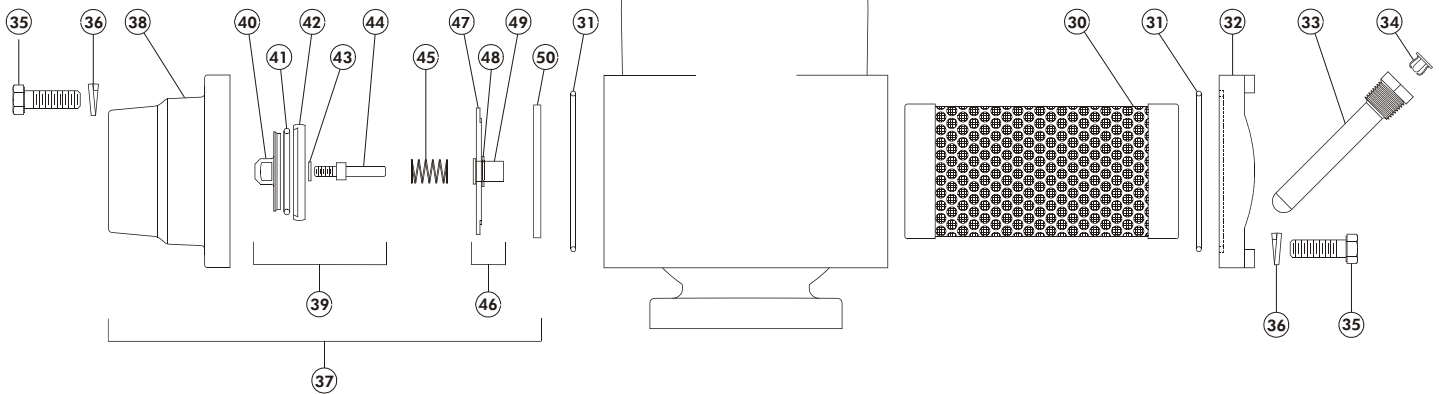

31	Gasket, o-ring, strainer cover	L100139-018
32	Strainer cover, for thermowell	L084811-701
	Strainer cover, no thermowell	L084812-702
33	Thermowell	L086666-702
34	Cover, thermowell	L083732-000
35	Screw, 7/16-14 x 1- 3/8", hex head	L000795-003
35	Lock washer, 7/16" steel	L041012-002
36	Stud, 5/8-11 x 2 1/4", steel	L082678-000
37	Inlet check valve, soft seat	L084813-702
38	Flange, inlet	L084814-003
39	Inlet check valve disk assembly	L084815-000
40	Retainer, disk	L100898-001

41	O-ring, soft seat	L100139-032
42	Holder, disk	L100374-002
43	Lock washer	L100121-009
44	Shaft, valve stem	L100896-001
45	Spring	L083492-010
46	Inlet check valve bearing support assembly	L084815-050
47	Bearing	L100899-010
48	Strap, inlet check	L084816-002
49	Retaining ring, 1/2"	L086071-000
50	Retaining ring, spiral	L084817-000
51	Caution tag, vapor return valve	L100333-001
NS	Caution tag, meter calibration	L100322-001

LPM-200

Replacement Parts

Differential Valve

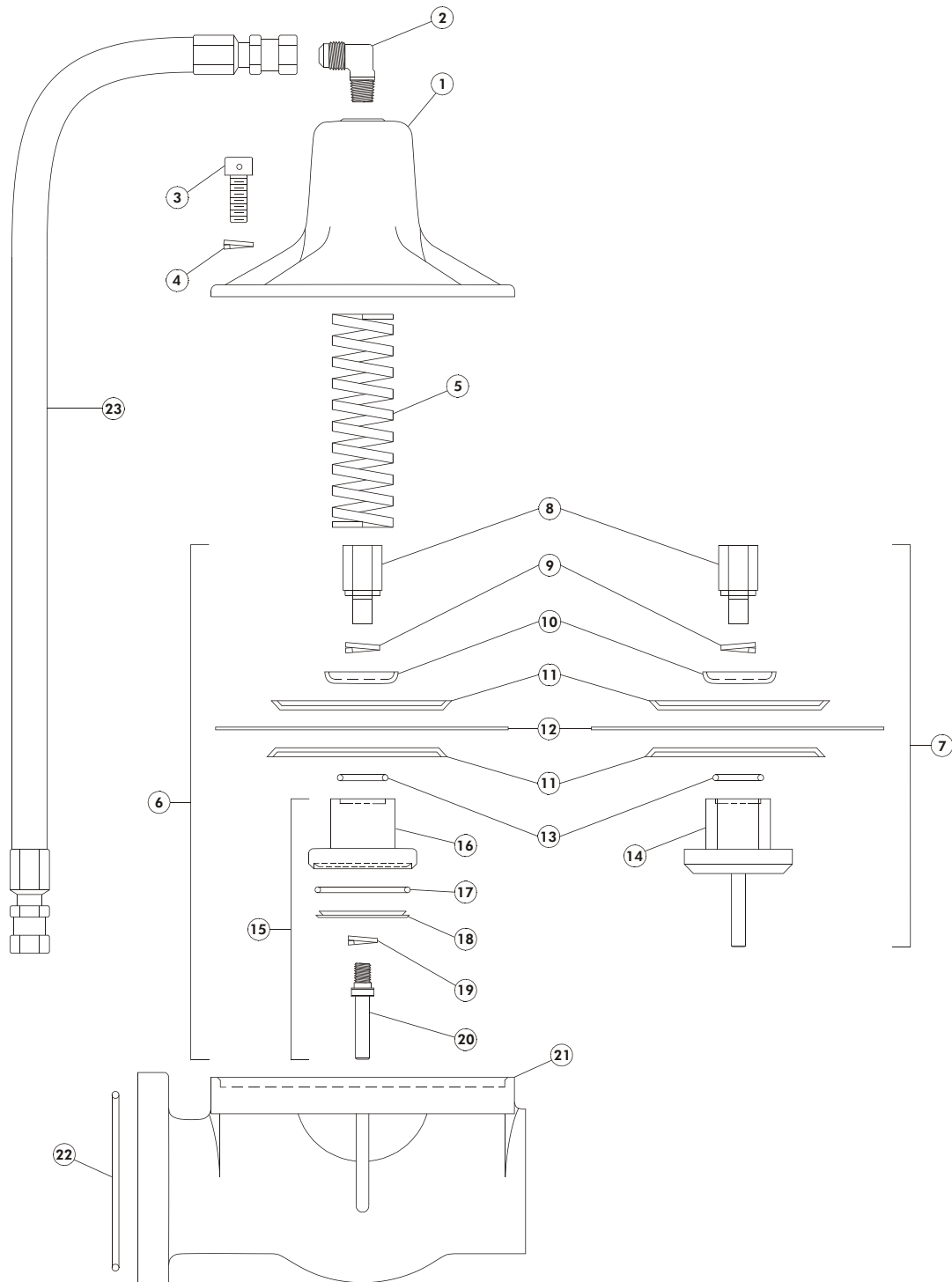

Ref.	Description	Part Number
1	Cover	L083766-701
2	Fitting, elbow, 3/8" NPT x 3/8" SAE	L084825-001
3	Screw, 3/8-16 x 1" socket head	L008325-014
	Screw, 3/8-16 x 1" socket head, drilled	L008325-015
4	Lock washer, 3/8" steel, high collar	L100440-002
5	Spring, valve	L083775-000
6	Diaphragm assembly, soft seat	L083947-010
7	Diaphragm assembly, hard seat	L083947-003
8	Screw, diaphragm	L083774-002
9	Lock washer, 7/16" steel	L041012-002
10	Retainer, spring	L083773-000
11	Retainer, diaphragm	L083772-002

Ref.	Description	Part Number
12	Diaphragm	L083771-002
13	O-ring, differential valve	L100139-001
14	Retainer, o-ring	L083927-002
15	Valve stem assembly, soft seat	L083927-010
16	Valve plug	L083927-011
17	O-ring, soft-seat	L100139-046
18	Retainer, o-ring	L083927-012
19	Lock washer, 3/8"	L100440-001
20	Valve stem, threaded	L083927-013
21	Body, differential valve	L083926-701
22	O-ring, flange	L10-0139-018
23	Hose, connector	L084823-010

Register Gear Plate Adapter, ATC

Ref.	Description	Part Number
1	Gear plate assembly, 1 1/4" - 2", ATC	L886205-001
2	S-shaft gear assembly, long knurled, w/41 tooth gear	L886112-004
3	R-shaft gear assembly	L886115-000
4	Shaft, output, w/spur gear assembly	L886116-010
5	Gear, bevel, w/clutch assembly	L886116-011
6	Washer shim, 1/4" x 1/2" x .005"	L886122-000
7	Retaining ring, 1/4", E-type	L886132-000
8	Washer shim, 3/16" x 3/8" x .010"	L886121-000
9	Retaining ring, 3/16" E-type	L886131-000
10	Washer shim, 1/4" x 1/2" x .028"	L886123-000
11	Register change gear assembly	L081230-XXX
12	Bushing, spacer, 1/4" x 1/2" x 1"	L000010-C02
13	Bushing, spacer, S-shaft, 1/4" x 1/2" x 1 1/4"	L000010-C06
NS	Bushing, R-shaft, 3/16" x 5/16" x 3/8"	L000010-C01

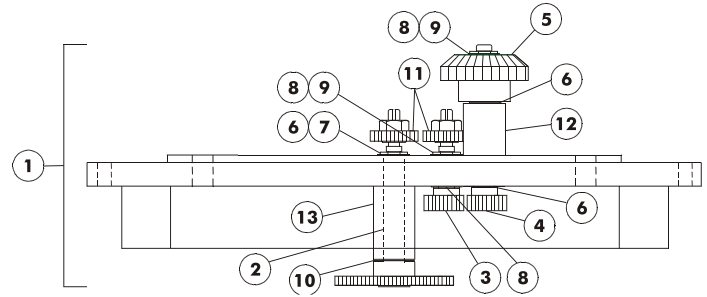

Register Gear Plate Adapter, No ATC

Ref.	Description	Part Number
1	Gear plate assembly, 1 1/4" - 2", non-ATC	L886201-001
2	S-shaft gear assembly, short	L886112-005
3	R-shaft gear assembly	L886115-000
4	Shaft, output, w/spur gear assembly	L886116-010
5	Gear, bevel, w/clutch assembly	L886116-011
6	Fork driver (short) w/pin	L088589-001
7	1/16" x 3/8" roll pin	L100370-003
8	Washer shim, 3/16" x 3/8" x .010"	L886121-000
9	Retaining ring, 3/16" E-type	L886131-000
10	Washer shim, 1/4" x 1/2" x .005"	L886122-000
11	Register change gear assembly	L081230-XXX
12	Bushing, spacer, 1/4" x 1/2" x 1"	L000010-C02
NS	Bushing, change gear shaft, 3/16" x 5/16" x 3/8"	L000010-C01

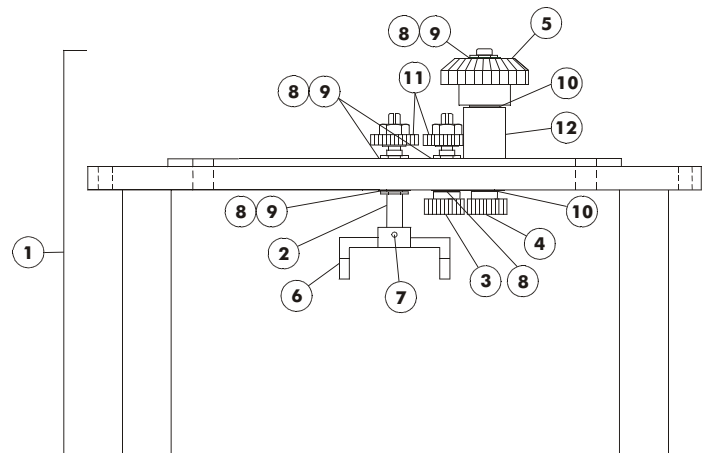

Meter Options

Strainer Magnet

Helps remove tank scale and other ferrous metal particulates in the liquid gas stream.

Part Number	Description
L101738-101	Strainer magnet



Trac-Bearing® Measuring Chamber

Provides greater sustained accuracy with less wear in low viscosity fluids. Patented design controls and stabilizes piston rotation better than standard control rollers.

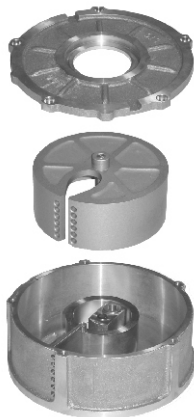

Part Number	Description
L045806-CHG	Upgrade, Trac-Bearing® chamber, LPM-200

Quick-Vent Flange

Replaces the strainer screen flange for safe and effective evacuation of meter. Route LPG to remote location or storage container. Controllable bleed rate. UL listed.

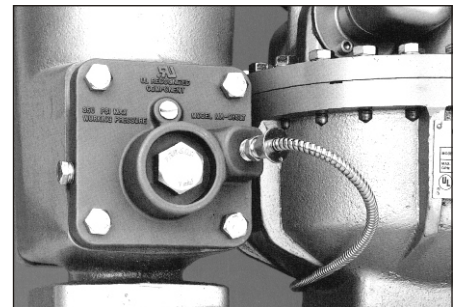

Part Number	Description
00MA20-CHG	Quick-Vent option on LPM-200 2" meters

