

# Nash Healey



## Car club

VOL. 6 NO. 4

JULY 1977



NASH-HEALEY Convertible Sports Car  
American Motors Corp.

Printed in U.S.A.

## PURPOSE & BENEFITS OF THE NASH HEALEY CAR CLUB

The Nash Healey Car Club is now an International Car Club for all Nash Healey owners and enthusiasts. Other Nash and other type Healey owners are also welcome to join. The Nash Healey Car Club has over 100 members in the United States, England, and the Virgin Isles.

It is our desire to promote the preservation, restoration and maintenance of all Nash Healey cars.

To unite all Nash Healey owners and enthusiasts of the marque.

To promote the showing of Nash Healey cars on a Regional and National scale.

To provide a source for all members in finding, buying, selling and trading Nash Healey cars, parts, and literature as well as other automobilia.

To publish a bi-monthly magazine for all members. This will include pictures, articles, technical points, restoration tips, and reports on Nash Healey meets, and news of Nash Healey's and other Nash and Healey cars, and a classified section (advertising will be Free for all members in this section).

All members will be entitled to, and encouraged to, send in news items, articles, and stories on restorations. Letters and pictures of members cars will a so be welcomed.

Membership dues for one year are \$6.00 for the United States and \$4.00 a year for England and other countries overseas. This includes a membership card, one year subscription to the Nash Healey Magazine (published bi-monthly) and a directory which lists all members and all known Nash Healey cars.

## EDITOR'S NOTES:

Nash Healey's are alive and doing well. There is now a West Coast Chapter of the Nash Healey Club. There are about 20 cars in California... I'm delighted. I keep on getting calls from people who are restoring cars that previously would not have been considered as a suitable start for a car. Cars without engines, cars with bad suspension castings, badly rusted cars. All now becoming full cars. The guy in Maryland who owns 24 Nash Healey's takes the position that every one of them is a potential car-even ones that are someone else's parts car. Well its on the way to that position.

Several Club members have suggested that we have an Eastern Meet. Well we're having it. I spoke to Ray Soles (our V.P.) and Frank Volmer, and Ray has made the arrangements. We are having a joint meet with The Butler OLD STONE HOUSE Region of AACA. Nash and Nash Healey cars are invited. There will be a Show and a Flea Market. If you want to set up a table, it's a very reasonable charge for space. It seems like a good way for a small marque to have a meet - with another group. Thus assuring those who come that there will be plenty to see and do. There are a number of motels in the area that can accomodate you if you care to stay.

Information on space:

James Tarr  
430 W. Sunbury Rd.  
Butler, PA 16001  
(412)285-3313



**TACHOMETER:** Does your tach. work? It is in fact small generator that is found in the distributor. It creates electricity and that is sent to the dash where it registers on a dial (the face of the tach.). The units were made by Stewart Warner. There are one or two private people in the country that still have parts and know how to fix them. I'll give you their names. I have no personal knowledge of their skill. I got their names from Stewart Warner in Chicago where there are no parts left.

It seems that the brushes wear out. Then--no electric and no tach. If you get intermittent use--this is probably worn brushes. I did however, speak to a man in New Jersey - Stewart Warner. I was impressed with his familiarity with the tach. units. He says he can adapt the parts from his remaining stock and the cost would be about \$15-\$20 to overhaul a distributor tach. generating unit. His name is:

Stewart Warner Repairs  
1075 Londons Rd.  
Union, NJ 07083  
(201)349-4050

Good Guy!

ATTN: Charles Stefanski  
Bob's Spedo & Clock  
15-255 Grand River Ave.  
Detroit, Mich. 48277  
(313)BR2-1050

Unknown

Western Battery & Magnito  
El Paso, Texas

-----  
Over-drive Relays:

There are two types: 1952 and '53-'54. The '52 type has seven lugs for wires and is about the size of a voltage regulator. It has two coils inside of it. I don't know where to get them. If anyone knows of another '50's car that had an over-drive and indicator light, let me know and I'll check on the units that were used. The second type was used in a number of Nashes in '49-'56 as the overdrive relay. An additional relay (a horn relay may well work) was used for the dash light. Thus, the late type (sic) relay is available, if not N.O.S. at least in a junk yard that has an overdrive Nash from the early '50's. ...Good Hunting!

Overdrive Cable: Is yours broken inside? What to do? Try this: Remove the inside cable from the shield. It is attached to the shaft by compression. I was unable to remove it from the hole it was in. I had to grind the shaft down to half thickness at the end to remove the old "nut" wire. Then I got some "music wire" (often called piano wire or spring wire) a similar thickness. This type of wire is the trick of the job. It is stiff, strong, and does what it is supposed to do. I then blazed it to the shaft. Too much heat is no good. A little oil and it is done. It was alot quicker than trying to find it as "N.O.S.".

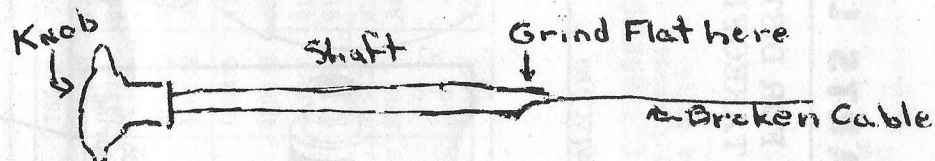

More yet on Windshields: One of the Club members called me about a windshield for a car he had just bought. I made a template and a curvature from my Roadster window, (The glass must be out of the frame for this), and sent it to Specialty Glass in California. They have now made a mold for Nash Healey Roadster windshields. This makes the first one cost about \$300-\$350. They tell me that for about \$150 they will make additional windshields for Roadsters. Originally I was discouraged by that company; they took a long time to answer and the price was too high. Well a new guy is in charge. It seems he took over and I spoke to him in the course of this template making. He seems very nice and a pleasant change from the previous owners. He mentioned that he had a Nash Healey Coupe windshield but I don't recall the price.

They can make any shape or curve of glass. Send them a pattern and a template. Stand Back; pay your \$; sane holds true for Nash Healey Coupe back windows.



# SERVICE PARTS LIST



## 762-SERIES SWITCHES FOR DISTRIBUTOR AND BUILT-IN TAKEOFFS

### DISTRIBUTOR SWITCHES

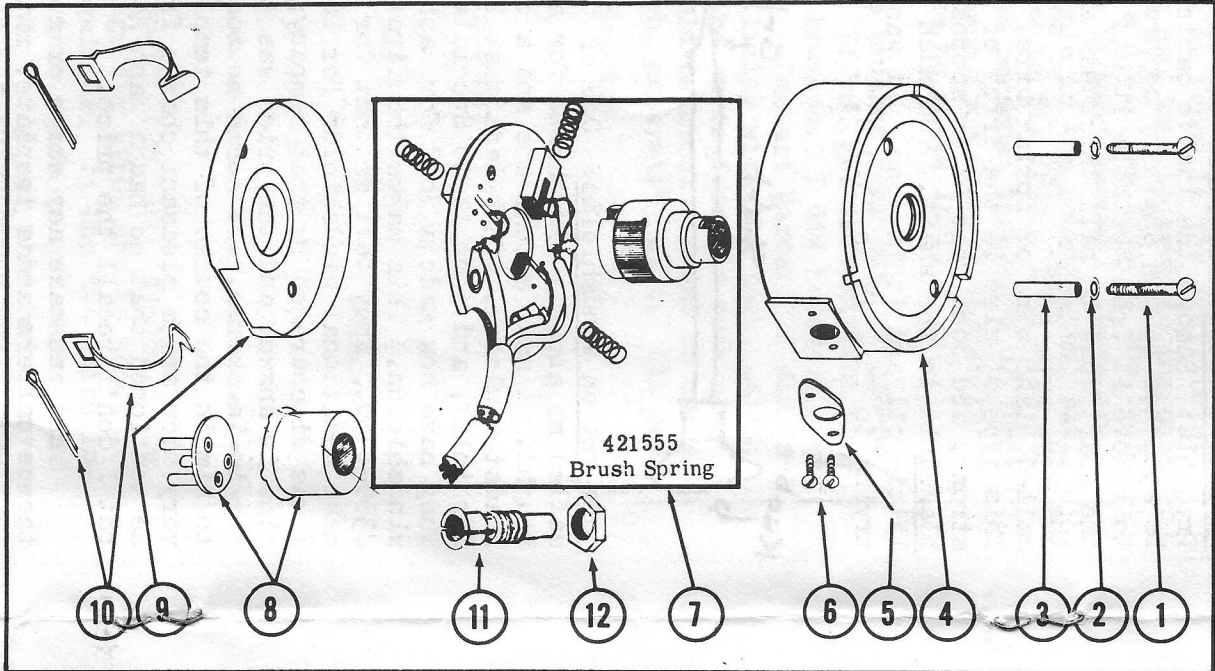

DESCRIPTION	762-H	762-J	762-K	762-M	762-P	762-S	762-AA	762-CC	762-DD
1. Screw	170262	170262	170262	170262	170262	170262	170262	170262	170262
2. Washer	79372	79372	79372	79372	79372	79372	79372	79372	79372
3. Insulator	171487-3	171487-3	171487-3	171487-3	171487-3	171487-3	171487-3	171487-3	171487-3
4. Housing	419147	423917	419144	419144	415303	420511	415234	415460	415303
5. Clamping Plate	419849	419849	419849	419849	419849	419849	419849	419849	419849
6. Screw	170665	170665	170665	170665	170665	170665	170665	170665	170665
7. Armature Brush Plate Assy.	420445	420445	420447	420449	420448	423871	420445	420446	420447
8. Plug	417969	417969	417969	417969	417969	417969	417969	417969	417969
9. Cover Plate	415238	415238	415238	415238	415238	415238	415238	415238	415238
10. Spring Clamp	415223	415223	419143	419143	415223	423872	415223	415223	415223
10. Cotter Pin	2581	2581	2581	2581	2581	Assem.	2581	2581	2581
11. Rotor Shaft	-o-	-o-	-o-	-o-	-o-	-o-	-o-	418733	-o-
12. Nut	-o-	-o-	-o-	-o-	-o-	-o-	-o-	418735	-o-
Brush Spring	421555	421555	421555	421555	421555	421555	421555	421555	421555

NOTES: -o- Indicates not used on this model.

Items 7, 8, & 10 furnished in Set only.

### STEWART-WARNER CORPORATION

1826 W. Diversey Parkway  
Chicago, Illinois 60614

Printed in U.S.A.

SER 762 (5-66)



NASH HEALEY CLUB ITEMS ORDER FORM

- N.H. bumper badge, quality made, 3" chrome N-H colors...\$6.95ea
- N.H. lapel pin or tie tac, miniature N-H emblem..... 2.25ea
- N.H. genuine leather key case (black w/silver)..... 1.50ea.
- N.H. litter bags, vinyl, (specify color-red, blue, green, black)..... .50ea
- Reprint of the 1953 8-page Nash Healey brochure..... 1.50ea
- Reprint of 1951 Nash Healey sales sheet..... .50ea
- Special Milestone Car Magazine with Nash Healey article, limited number available..... 3.00ea
- Special Interest Auto Magazine, Volume 1, No.1, with Nash Healey article, rare, original..... 2.00ea
- Back issues of Nash Healey Magazines:
  - Vol.1 No.2( ) No.3( ) No.4( ) No.5( ) No.6( )
  - Vol.2 No.1( ) No.2( ) No.3( ) No.4( ) No.5( ) No.6( )
  - Vol.3 No.1( ) No.2( ) No.3( ) No.4( ) No.5( )
  - Vol.4 No.1( ) No.2( ) No.3( ) No.4( )
  - Vol.5 No.1( ) No.2( )

NOTE: ALL back issues are 75¢ each

BRAND NEW FRONT END PARTS

- Eccentric mounting pins for shock absorbers.....\$20.00ea.
- Knuckle spindle..... 74.00ea.
- Sway Bar Anchors..... 10.00ea.
- Outer bearing felt washers (for trailing link rear end)..... 4.00ea.
- Sway bar sleeves..... 6.00ea.
- Bearing retainer screw..... 4.00ea.
- Thrust washers for king pins..... 3.00ea.
- SPECIAL - 60 DAYS ONLY - N-H cross flag emblem \$9.95 (limit one)
- Brand new FARINA fender emblem..... 17.00
- Carb. repair kits for S.U. carbs..... 5.95ea.
- Carb. repair kits for Carter carbs..... 4.95ea.

Richard Kauffman  
100 Church St.  
Lakeland, GA 31635

Brand new parts for Nash Healey-

- Complete set of king pins and bushings .....\$60.00
- Parking lite lens..... 2.30
- Complete parking light assembly(less lens)..... 14.50
- Taillight lens..... 3.95
- Fan Belt..... 4.95
- Voltage Regulator..... 18.95
- Ignition Coil..... 14.95
- Ignition Tune-up kit..... 5.95
- Brake Master Cylinder Repair Kit..... 5.95
- Wheel cylinder repair kit..... 3.95
- Starter solenoid..... 9.95
- Light dimmer switch..... 3.95
- Brake hose..... 5.95
- Fuel pump..... 16.95
- Water pump..... 26.95
- Front wheel bearings (inner or outer)..... 6.95
- Piston ring set(3 1/2 in. bore)..... 26.95
- Starter drive..... 9.50
- Exhaust valves-set of six..... 26.95
- Intake valves-set of six..... 22.95
- Horn relay..... 5.95
- License plate lamp holder (orig.)..... 25.00
- N-H type trunk handle(without lock cylinder)..... 7.00
- Set of chrome lock latch strikers for trunk..... 12.00
- Set of chrome door pulls(2)..... 15.00
- set of six piece chrome trim for crash pad('52-'54) 25.00
- Rebuilt water pump..... 15.00
- Set of rear coil springs(like new)..... 15.00
- (for above) shipping 4.00

USED PARTS

- Used brake drum(for '52-'54)..... 15.00
- shipping... 5.00
- Used damper pulley..... 8.00
- shipping... 3.00
- Used universal joint..... 6.00
- shipping... 2.00
- Used front end ball joint..... 20.00
- Used bracket part no.H5197..... 5.00
- Used part no.H3043..... 5.00
- Used part no.H4611..... 2.00
- Used stay cover trunk hinge..... 3.00

Send orders to:

Richard Kauffman  
100 Church St.  
Lakeland, Ga. 31635

CLASSIFIED

WANTED: harness, new head for engine (Pina Farina Body) Howard Kapso, 1323 Home Ave., Berwyn, Ill. 60402

WANTED: 1951-54 Nash Healey Roadster or Coupe. Must be excellent condition. Restored or original. Prefer mid-West area. Allan Thomann, 206 Edwards St., Danville, Illinois 61832 (217) 442-8929

WANTED: Wiring harness for 1951 Nash Healey, R.W. Nash, Rte.#1, Box 490A Old Church, Mechanicsville, Virginia 23111

WANTED: Crossed flags, N.H. trunk lid - grill medallion-chrome 3 piece or aluminum at door bottom-Pina Farina letters for front fender. Charles Olson, 661 Logan La., Danville, Calif. 94526

WANTED: The complete front and rear bumpers for a 1953 Nash Healey. Also, overdrive relay, radio, - speakers, center grill ornament, 2-inside door handles, gas-cap handle. Rudy Franco, 740 Sampson St., San Diego Calif. 92113 (714)232-8845

WANTED: Tail-light rims, one original parking light, set of side curtains with or without plexiglass, Nash Healey script for trunk. Ray Hren, 7661 Tall-Pine Lane, Roseville, Calif. 95678

WANTED: Two tail-light lenses for 1953 Nash Healey Hard Top. Mark Morgan, 1911 Hughey St., Kissimee, Florida 32741

FOR SALE: 1953 Nash Healey Roadster, completely restored in 1972, super charged. Paul Shaw, 528 E. College St., Iowa City, Iowa 52240

Classified continued

FOR SALE: 1953 Nash Healey Coupe, 62,853 miles, willow green with tan interior, partially restored, \$6,000. Also selling 3 moon hub-caps. Mark Morgan, 1911 Hughey St., Kissimee, Florida 32741

FOR SALE: 1952 Nash Healey Roadster, presently under restoration, body in prime & in very good condition. Windshield cracked but has extremely rare wire wheel covers with "N" in cap. \$4,000. firm. Contact - Ron Ayers, 405 Cheyenne Dr., Simpsonville, S.C. 29681 1-803-963-8917

FOR SALE: 1952 Roadster - will part out - contact Peter A. Williams, P.O. Box 16, Village Station, New York, NY 10014 (212) 691-2301

FOR SALE: 1952 N.H. Roadster, new convertible top, \$4,500. contact Jacque Harguindeguy, 167 Richard La., Walnut Creek, Calif. 94595 (415)934-5499

WANTED: 2 new carbs., 1 new fuel pump, exhaust system, dash knobs, round "N" insignia bet. grill bars, licence plate light. Contact David A. Jones, 279 Legion Way, Cranston, R.I. 02910



FROM: Peter Williams  
P.O. Box 16  
Village Station 29  
New York, N.Y. 10014



Ray Soles - Addison, PA  
1953 Nash Healey Roadster



TO:

Jacques Harguindeguy  
167 Richard Lane  
Walnut Creek, CA 94595  
CA.

FIRST CLASS MAIL